



Digital 280

Digital indicator



4-digit display in red or green

Universal input and input signal correction

Freely scalable

Two relay outputs

RS 422/485 interface

Analog output

PROFILE

In all industrial applications where temperatures, pressures or other physical parameters have to be displayed, the Digital 280 can be used. The universal input circuit allows to connect thermocouples, resistance thermometers and all other sensors with voltage or current output. The feature „one version for all input sources“, (no plug-in modules or configuration jumpers) fulfils the prerequisite for the reduction of instrument stock and as result the reduction of costs.

The input signal can be scaled, monitored for limits or for sensor break. Two relays signal the limit condition. Additionally the displayed value can be accessed to the analog output as a 0 or 4 to 20 mA current signal.

In industrial applications with distributed measuring points, on-site display and for central data acquisition the Digital 280 with RS 422 interface is the ideal instrument.

Alternatively the Digital 380 can be used, which has intrinsically safe inputs, mathematical functions and supports the intelligent channel selector / scanner unit.

DESCRIPTION

The Digital 280 is suitable for connecting thermocouples, resistance thermometers, potentiometric transducers and current/voltage signals.

Thermocouples can be measured with internal or external cold junction compensation. Resistive thermometers and resistors can be connected in 3- or 4-wire technique.

Sensor monitoring

Resistance thermometers, thermocouples, and resistance transducers are always monitored for breakage.

Input signal correction

Input signal correction is used to match sensor and indicator for tolerance-compensated readings and fulfils the calibration standard of ISO 9001.

Two different corrective methods are available:

- correction „on the process“ within the limits of the selected span or
- selection of values from the calibration table (scaling).
(calibration device 701/702 on request)

Subsequent corrections during operation are possible by means of the front keys. The curve can be adjusted for offset and gain.

Limit signalling

- One minimum and maximum alarm for each relay (adjustable in engineering units)

Hysteresis

Separately configurable in engineering units for each relay.

Discriminator (response delay)

Configurable from 0...9999 s. All alarm signals shorter than the selected delay are ignored.

Signalling

- two red LEDs in front panel (lights up on alarm)
- via relay output (NO or NC operation)

Alarm latch (Software option)

The alarm condition is latched until it is reset by front key or digital input (d1).

Filter

The input has a 1st-order mathematical filter. It is adjustable for time constant and bandwidth.

The bandwidth is the tolerance above and below the process value, in which the filter is active. Changes of the process value larger than the adjusted bandwidth are not filtered and displayed directly.

Fig. 1 Noisy input signal

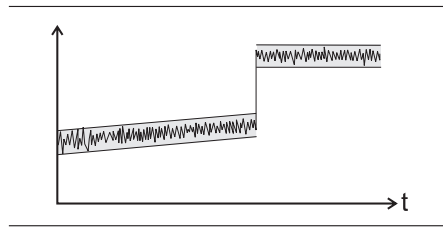
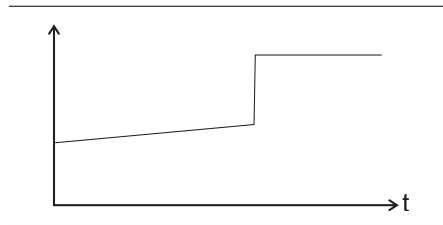

Fig. 2 Smooth display and analog output



TECHNICAL DATA

INPUT

Resolution of approx. 20.000 steps referred to full span.

Measuring sequence: 200 ms

Thermocouples

Linearization: built in

Display in °C or °F

Input resistance: > 1MΩ

Influence of source resistance: approx. 0,5 mV/Ω

Cold junction compensation internal or external with adjustable reference temperature 0...60°C

Break monitoring via sensor current 0,5 μA

Resistance thermometer

Pt100 DIN/IEC with built in linearization

Display in °C or °F

Connection

three or four-wire

Lead resistance: ≤ 30 Ω per wire

Input resistance: > 1 MΩ

Sensor monitoring: for break

Resistance & potentiometric transducer

Connection

Transducer: three-wire

Resistance: three or four-wire

Lead resistance: ≤ 30 Ω per wire

Input resistance: > 1 MΩ

Sensor monitoring: for break

Table 1 Thermocouple measurement

Sensor	Type	Input range		Display error	Resolution
Fe-CuNi (DIN)	L	-100... 900 °C	-148... 1642 °F	≤ 3 K ± 1 digit	< 3 μV
Fe-CuNi	J	-100... 1200 °C	-148... 2195 °F	≤ 3 K ± 1 digit	< 3 μV
NiCr-Ni	K	-100... 1370 °C	-148... 2498 °F	≤ 3 K ± 1 digit	< 3 μV
PtRh-Pt 10 %	S	0... 1760 °C	38... 3200 °F	≤ 3 K ± 1 digit	< 1 μV
PtRh-Pt 13 %	R	0... 1760 °C	32... 3200 °F	≤ 3 K ± 1 digit	< 1 μV
PtRh-Pt 6 %	B	0... 1820 °C	32... 3308 °F	≤ 3 K ± 1 digit*	< 1 μV
Cu-CuNi	T	-100... 400 °C	-148... 752 °F	≤ 3 K ± 1 digit	< 3 μV
Nicrosil/Nisil	N	-100... 1300 °C	-148... 2372 °F	≤ 3 K ± 1 digit	< 3 μV
NiCr-CuNi	E	-100... 1000 °C	-148... 1832 °F	≤ 3 K ± 1 digit	< 3 μV
W5%Re-W26%Re	W(C)	0... 2315 °C	32... 4199 °F	≤ 3 K ± 1 digit	< 3 μV

* in the range 400...1820 °C

Table 3 Resistive measurement

Sensor	Sensor curr.	Input range		Display error	Resolution
Pt100 DIN	0,4 mA	-200... 650 °C	-328... 1202 °F	≤ 1 K ± 1 Digit	< 15 mΩ
Resistance	0,4 mA	0... 400 Ω	-	≤ 0,05 % ± 1 Digit	< 15 mΩ
Resistance	0,1 mA	0... 1500 Ω	-		< 55 mΩ

Table 3 Direct voltage and current

Input span	Input resistance	Display error	Resolution
- 3... 23 mV**	> 1 M Ω	≤ 0,05% ± 1 digit	< 1 μV
- 11... 69 mV**	> 1 M Ω		< 3 μV
0... 160 mV**	> 1 M Ω		< 6 μV
- 0,6... 4,4 V	approx. 100 kΩ		< 200 μV
- 2... 13 V	approx. 100 kΩ		< 600 μV
0... 30 V	approx. 100 kΩ		< 1,2 μV
- 1... 7,3 mA	18 Ω	< 0,3 μA	
- 3... 22 mA	18 Ω	< 1 μA	
0... 50 mA	18 Ω	< 2 μA	

** Break monitoring via sensor current of 0,5 μA

Fig. 3 Overall dimensions (mm)

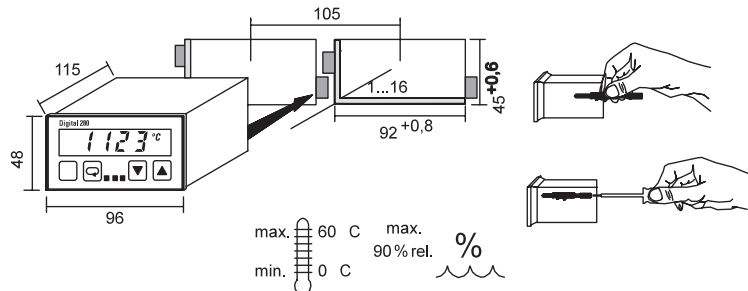
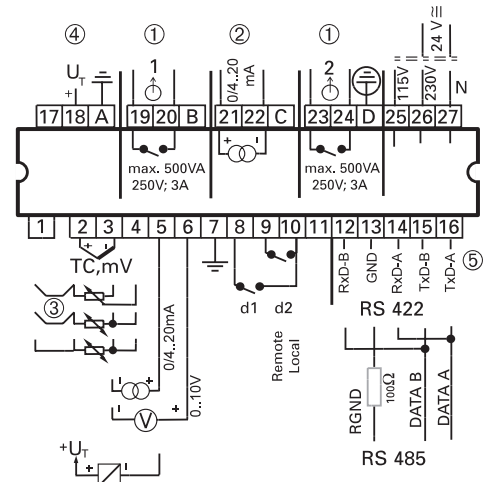

Fig. 4 Electrical connections

- ① Option, relay of alarm 1/2
- ② Option, analog output current 0/4...20 mA
- ③ RTC-3-wire and potentiometric transducer: link at the terminals
- ④ Transmitter power supply only with order no. 9407-300-xx0x1 and 9407-300-xx1x1
- ⑤ Interface (only with order no. 9407-300-xx2x1)



Direct voltage and direct current

see table 3

Control inputs

Control input for potential free contact or logic signal 0/5V

d2 (Remote/local)

Contact opened or 5V: local operation

Contact closed or 0V: remote operation (writing via interface is allowed) resp. parameter level locked.

d1 (Software option)

Contact opened or 5V: no reset

Contact closed or 0V: reset alarm (Con4)

Permissible interference at input

(to DIN IEC 770 6.2.4)

Common mode suppression: negligible

Series mode: no effects up to

450 mV_{rms} for TC (Type S)

1 V_{rms} for mV (0...50mV)

750 mV_{rms} for Pt100 (0... 100°C)

10 V_{rms} for DC 0...4V/0...5mA

TRANSMITTER POWER SUPPLY

Only with versions without interface and without analog output!

Voltage $U_T > 13V$ for 20mA, not short circuit proof

OUTPUTS (optional)

Analog output (optional)

0...20 mA or 4...20 mA freely scalable

Signal range: 0... 22 mA

Load: $\leq 500 \Omega$

Resolution: $\leq 0,1$ mA (8 bit)

Sensor monitoring

Output action selectable upscale or downscale

Relay outputs (optional)

Reaction time for 0 to 90%: 200ms

1 or 2 relays with potential free switchover contact

Contact rating:

max. 250VAC; 3A; 500VA; resistive load min. 10 V DC; 0,05A; 1VA

Normally opened or normally closed

Operating mode: selectable for input circuit monitoring and/or limit signalling

POWER SUPPLY

Two versions:

115/230VAC, -15...+10% or

19...30VDC or 24V AC, -15%, +10%

Power consumption: approx. 5 VA (W)

Frequency: 48...62 Hz

Behavior at mains failure

No loss of calibration, parameter and configuration data

DISPLAY

4-digit LED in red or green, 14mm high

2 red LEDs: input circuit monitor or limit signaller activated

yellow LED: remote (operation via interface allowed, no local operation)

OPERATION

Configuration, parameter setting, and input signal correction are menu-guided via three front-panel keys.

Lock function

Digital input d2 can be used for locking purposes:

- Locking of complete operation
- Locking of parameter level

SERIAL INTERFACE (optional)

Built in RS422/485 interface provides reading of process data and reading/writing of parameter and configuration data.

Galvanically isolated

Transmission rate 2400...19200 bits/s

Address 00...99

Drivers for WIZCON, FIX DEMACS and InTouch are available.

Fig. 5 Parameter setting and configuration

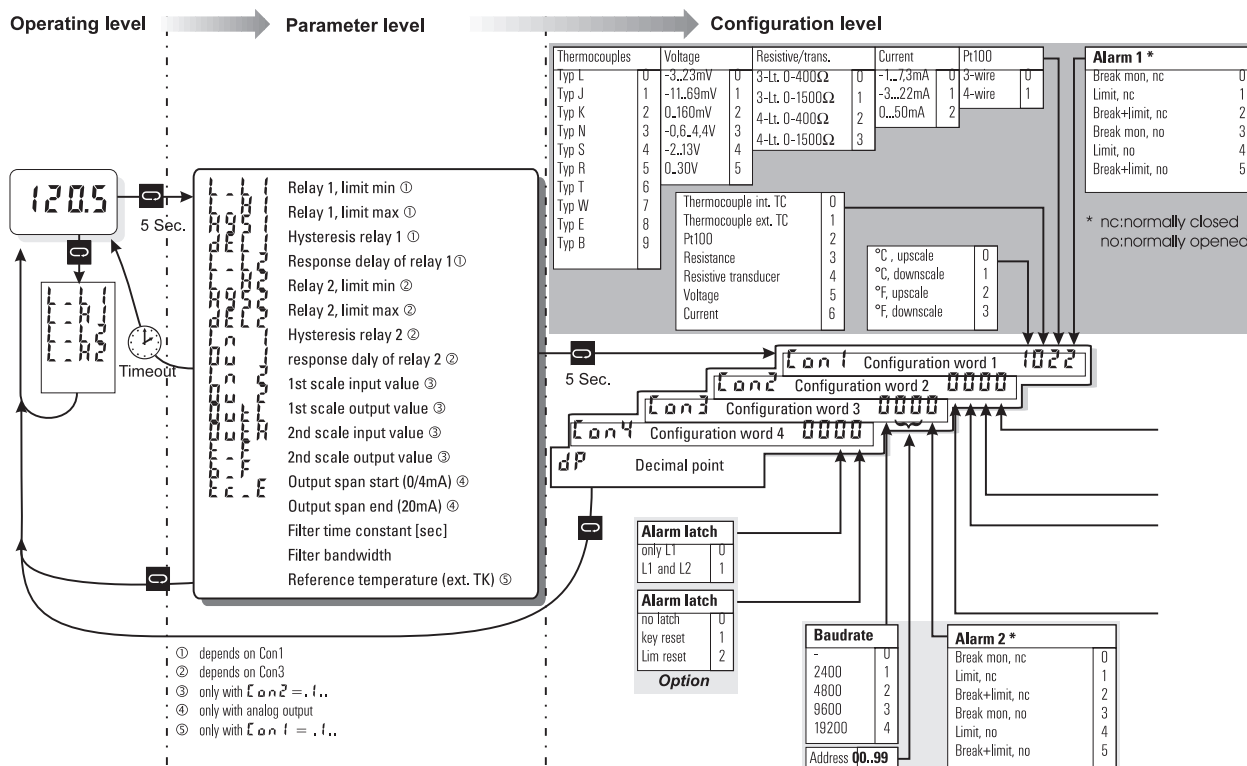

COMPUTING FUNCTIONS

- 1st-order filter with adjustable operating range (bandwidth)
- Input signal correction

Software options

Alarm latch

The alarm condition is latched until it is reset by front key or digital input (d1). Alarm condition is latched even after mains failure!

ENVIRONMENTAL CONDITIONS

Temperature limits

For specified accuracy: 0... 55°C

For operation: 0... +60°C

For storage: -20... +70°C

Influence of internal cold junction compensation: < 0,5 K/10K

Relative humidity: < 90% RH, no condensation

Shock and vibration

DIN IEC 68-2-6/Fc
DIN IEC 68-2-29/Eb

ELECTROMAGNETIC COMPATIBILITY

Complies with EN 50081-1 and EN 50082-2 for unlimited use within rural and industrial areas

Interference on input and output leads
EN 61000-4-4, Level 4: 2 kV CM¹⁾Burst
EN 61000-4-5, Level 3: 2kV CM¹⁾ and 1kV DM¹⁾

High-frequency interference
EN 61000-4-3, Level 3: 10V/m
No effect with 27... 1000 MHz²⁾

Interference on leads
EN 61000-4-6: 10 V_{rms}
No effect with 0,15... 80 MHz²⁾

Electrostatic discharge
EN 61000-4-2, Level 3
No effect with 8 kV air discharge;
4 kV contact discharge (*via coupling plate*)

Low-frequency magnetic field
400 A/m, 50 Hz

¹⁾ CM = Common Mode, DM = Differential Mode

²⁾ Related to full span

ORDERING DATA

115 / 230 V AC	0	↑	↑	↑	1
24 V UC (universal supply)	1				
Red display	0				
Green display	1				
Red display + software options	2				
Green display + software options	3				
Indicator (with transmitter power supply)	0				
Indicator with 2 relays (with tps)	1				
Indicator with 2 relays and RS 422 interface	2				
Indicator with 1 relay and analogue output	3				
Indicator with 2 relays and analogue output	4				
Standard configuration	0				
Customer specific configuration	9				

Accessories and documentation

Interfacedescription	9499 040 49941
MSI Server – 32 Bit DDE-Server	9407 999 07101
Converter RS 232 to RS 422 (incl. RS 232 cable, 10 m cable RS 422)	9407 998 00041

GENERAL

Housing

Plug-in module, inserted from front
Material Makrolon 9415 flame-retardant, self-extinguishing.
Flammability class UL 94V0

Protection mode

DIN VDE 0470 / EN 60529
Front: IP 52
Housing: IP 20
Terminals: IP 00

Safety characteristics

According to EN 61010-1:
Overvoltage category III
Pollution degree 2
Operating voltage range 300 V
Protective class I

CE-marking

According to European Directives for „Electromagnetic compatibility“ and „Electrical equipment use within specified voltage limits“ (see Safety Characteristics)

Electrical connections

Flat-pin connectors to DIN 46 244 for 1x6,3 mm or 2 x 2,8 mm

Mounting method

Panel-mounting with two fixing clamps at the sides

Weight

approx. 0,4 kg

Accessories

- Operating manual 9499 040 47801
- 1 sheet of adhesive labels with engineering units
- 2 mounting clamps
- seal (front/panel)

PMA
Prozeß- und Maschinen-
Automation GmbH
P.O. Box 31 02 29
D-34058 Kassel
Tel.: +49 - 5 61 - 5 05 14 03
Fax: +49 - 5 61 - 5 05 16 61
e-mail: export@pma-online.de
Internet: http://www.pma-online.de

Your local representative: