



KS 3012

6 / 12 universal inputs

7 digital inputs

Data acquisition with a sampling rate of 125 ms

CF card as data storage medium

Use as point or line recorder

Visualization in up to 6 groups

Modbus interface

Profibus DP interface

Ethernet interface

GENERAL

The data monitor KS 3012 is a freely programmable, microprocessor-controlled device for measuring, storing, visualizing, and analysing process data. The KS 3012 is available with 0*, 6 or 12 universal inputs. Measured data are stored in a RAM, where they are available for display on the colour screen.

In addition, the data are saved on an external storage medium (CF card). By means of an optional PC-based program, the data are also made available for subsequent evaluation and analysis. The data monitor KS 3012 is intended for use in industrial applications, and is designed for panel mounting in a cut-out of 138 x 138 mm.

DESCRIPTION

Data measurement & acquisition

The KS 3012 is fitted with 0*, 6 or 12 analog inputs for direct current/voltage signals, thermocouples, resistance thermometers, and potentiometric transducers.

Sensor type and measurement range are freely configurable. Internal linearization is provided for thermocouple and resistance thermometer signals. Inputs are galvanically isolated by means of opto-couplers.

With 6 and 12 inputs, the sampling rate is fixed at 125 ms, enabling the unit to be used as a point or line recorder. The version without analog inputs (connection via Profibus-DP interface) can handle up to 36 input signals. As an option, 7 digital inputs can be fitted in addition to the analog measurement inputs.

Operation and configuration

Operation and configuration are menu-guided by means of 8 keys in the front panel. Unauthorized access to the unit's configuration can be password-protected.

Configuration data can be saved to a storage medium from the KS 3012, or read into the KS 3012 from a storage medium. By means of an optional Engineering Tool, the unit can be configured via a PC.

The Engineering Tool (English, German, or French) enables the following languages to be selected for operation and configuration: English, German, French, Spanish, Italian, Czech, Swedish, Finnish, Russian, and Danish.

PC-based evaluation software

This optional software package runs under Windows 95/98/XP/2000 or NT, and is used for visualization, evaluation, administration and archiving of measurement data stored by the KS 3012. Data can be read from the stor-

age medium or via the optional RS 232/422/485 or Ethernet interface by means of the optional PCA communication server.

The communication server allows a timed read-out of data stored in the RAM of the KS 3012 via the selected interface.

The available functions are as follows:

- The data from differently configured monitors is recognized and stored in a database. The entire data administration is executed automatically; the user only has to enter an identifier.
- The user always has direct access to data that has been specified by means of the identifier. Furthermore, the periods to be evaluated can be limited.
- New display groups can be configured at any time by assigning the required analog and digital inputs.
- Every group is displayed in its own window. Two or more groups can be displayed simultaneously, e.g. for comparison.
- An export filter enables the data to be transferred to other programs, e.g. Excel, for further calculations.

Visualization

For visualization, the KS 3012 is fitted with a 5,7-inch (145 mm) STN colour graphics display with a resolution of 320 x 240 pixels.

* with Profibus dp

A 16-value grey scale and 27 colours ensure brilliant displays. The KS 3012 handles up to 6 display groups, whereby each group can contain 6 analog and 3 digital inputs. Within each group, different display formats are possible: vertical/horizontal diagram, individual and group data in numeric form, and bargraph displays.

The vertical and horizontal diagram can be switched over to show a historic display of the stored data in the RAM, e.g. for analysis. Various reports can be generated for every analog input signal, e.g. periodic or external, as well as daily, monthly, or annual reports.

Batch records

In connection with an external report, it is possible to generate batch records. Hereby, start, end, and duration of a batch are recorded. Moreover, a batch counter provides the following functions:

- automatic incrementing of the batch number
- can be edited manually
- recipe handling is possible, whereby the batch record can be started e.g. via:
 - digital inputs 1...7 (option)
 - Modbus flag (serial interface)

Data processing

The input values are sampled continuously at fixed intervals of 125 ms, and are stored in a buffer memory. Hereby, an exceeded limit value triggers an alarm. This alarm signal can be used e.g. to switch the storage mode from the normal (timed) mode to the event-driven mode.

Storage cycle and stored value are separately configurable for all three operating modes. Normal mode is the default setting, i.e. if the data recorder is not switched to timed or event-driven mode.

The event mode is triggered by an external signal (digital input, group or common alarm, etc.). It remains in this mode as long as the trigger signal is present.

The timed mode is executed once a day during a pre-programmed period.

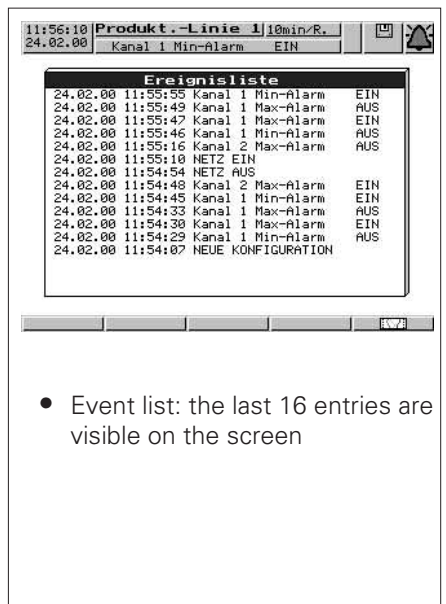
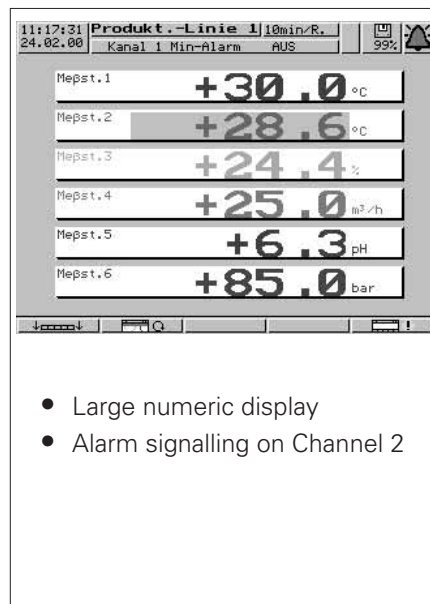
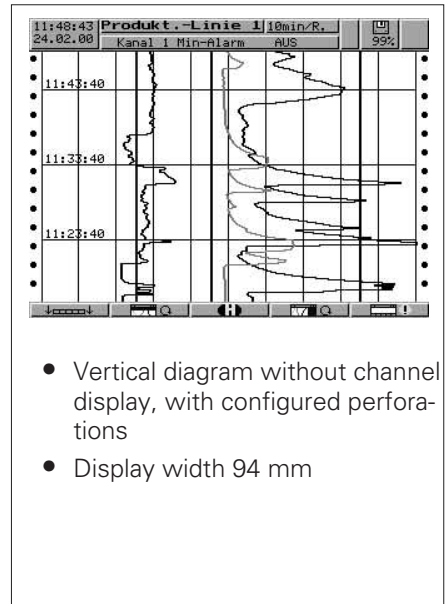
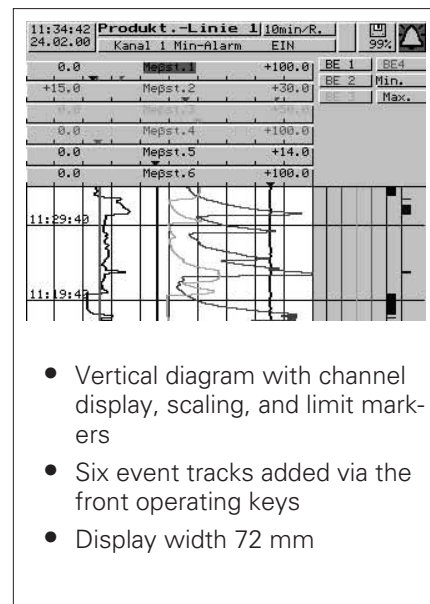
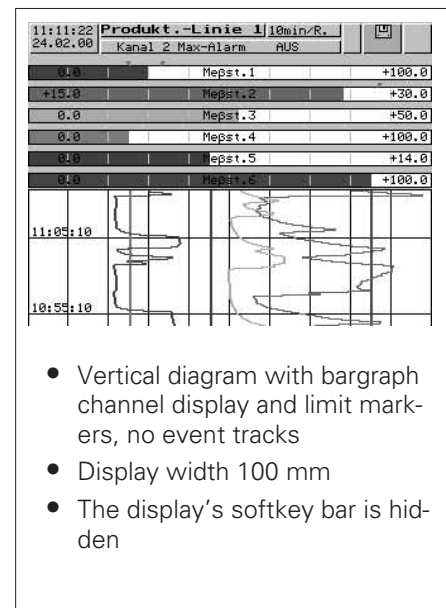
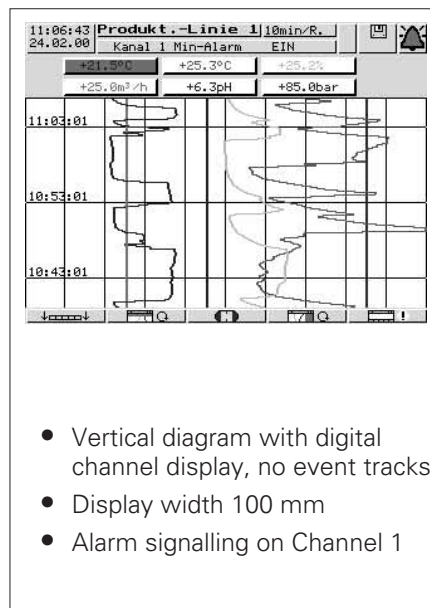

The operating modes have defined priorities: Event mode prior to timed mode, timed mode prior to normal mode. Data stored in the RAM are copied onto the storage medium at regular intervals.

The RAM is operated as a ring buffer, i.e. when it is full, the oldest data are overwritten by the newest data. A Compact Flash card with a capacity of 32... 128 Mbytes is used for data storage.

Every 'data write' operation is verified, so that errors are detected immediately. The unit monitors the remaining capacity of the storage medium, and generates a „reserve storage" alarm as soon as a pre-defined minimum capacity is reached. The alarm signal can be used to trigger a relay (e.g. „change storage medium"). By selecting the „storage medium update" function before the storage medium is removed, the unit copies any data from the RAM that has not yet been saved.

Measurement data are stored by means of a special encryption code. If the storage medium is removed from the unit, there is no immediate loss of data, because operation of the RAM is not affected.

Only when the RAM is full, and the storage medium has been removed, will old data be overwritten. The unit remembers which data from the RAM have already been copied to the storage medium.

As soon as a new storage medium is inserted, any data not yet saved will be copied from the RAM immediately.

If old data has already been overwritten due to a missing storage medium, the entire RAM contents are copied as soon as a new medium is inserted.

The available storage capacity depends on the configuration of the KS 3012, and can vary from a few minutes up to several months.

Example:

1 group with 6 analog channels, storage cycle 30 s (CF card with 32 Mbyte).

This results in a storage capacity of approx. 1 year, 8 months, and 26 days for the CF card and the RAM. If a longer storage cycle is used for normal operation, e.g. every 2 minutes, the recording capacity is increased 4-fold.

The event recording mode can also be used to switch over to a shorter cycle time in case of an alarm. This means that a „generous" cycle time can be configured for normal, trouble-free operation to provide sufficient data e.g. for a daily trend record. As soon as a special condition (event) occurs, which requires a more detailed record, the KS 3012 is switched into the event recording mode (short cycle time).

Interfaces

The actual process data (analog signals and digital events) and special monitor data can be output via the RS 232, RS 422/RS 485 or Ethernet interface.

As standard, the KS 3012 is fitted with the RS 232 interface, which allows up to 15 m of cable. With RS 422/RS 485, cable lengths up to 1,2 km are permitted.

The transmission protocol is Modbus. By means of the optional PCA communication server, it is possible to read the data stored in the RAM of the KS 3012 via the RS 232, RS 422/485, or Ethernet interfaces, or via modem. Data readout can be started manually or automatically (timed). Furthermore, the Modbus interface permits up to 24 external analog inputs and 6 digital inputs to be connected to the KS 3012. In the version with a Profibus-DP interface, the KS 3012 can be operated as a slave in a field bus system in accordance with the Profibus-DP standard.

Via this interface, up to 36 external analog inputs and 6 external digital inputs can be handled by the KS 3012 for visualization and recording purposes. Moreover, the data of the internal 6/12 analog inputs and max. 6 internal digital inputs can be read out of the KS 3012.

Data is transmitted at max. 12 Mbit/s. With the help of the projecting tool „GSD generator" (supplied), an application-specific GSD file is produced, with which the KS 3012 is linked into the field bus system.

Optionally, an Ethernet link (10BaseT) can be provided for the KS 3012. By means of this link, the unit's parameters can be set remotely. Similarly, the stored data can be read out manually or via the optional PCA communication server.

TECHNICAL DATA

Analog inputs

Configurable for sensor type and measuring range. Galvanic isolation between inputs: up to 30 VAC or 50 VDC by means of opto-couplers.

Scanning cycle

6 or 12 inputs every 125 ms
Resolution >14 bits

Thermocouples

Smallest span: 100 K

Type	Measurement range
Fe-CuNi „L"	-200...+900 °C
Fe-CuNi „J"	-210...+1200 °C
Cu-CuNi „T"	-270...+400 °C
Cu-CuNi „U"	-200...+600 °C
NiCr-CuNi „E"	-270...+1000 °C
NiCr-Ni „K"	-270...+1372 °C
NiCrSi-NiSi „N"	-270...+1300 °C

Measurement error: $\pm 0,1\%$ referred to max. measuring range, **plus the CJC error** (only guaranteed above -100 °C with Type J, above -150 °C with Types U and T, and above -80 °C with Types K, E, and N).

Smallest span: 500 K

Type	Measurement range
Pt10Rh-Pt „S"	-50...+1768 °C
Pt13Rh-Pt „R"	-50...+1768 °C
Pt30Rh-Pt6Rh „B"	0...+1820 °C

Measurement error: $\pm 0,15\%$ referred to max. measuring range, **plus the CJC error** (only guaranteed above 400 °C with Type B, and above 0 °C with Types S and R).

Span start and end of span can be configured freely in steps of 0,1 K within the specified max. measuring ranges.

Cold junction compensation CJC

Internal: Pt 100

Error: $\pm 1,0$ K

With an external reference, the cold junction temperature is configurable in the range -50...+100 °C.

Resistance thermometer

Two, three or four-wire connection possible.

Smallest span: 15 K

Type	Measurement range	Linearization
Pt 100	-200...+850 °C	DIN
Pt 100	-200...+650 °C	JIS
Pt 500	-200...+850 °C	DIN
Pt 1000	-200...+850 °C	DIN
Ni 100	-60...+180 °C	DIN

Measurement error: $\pm 0,4K$ for $-200...+500\text{ }^{\circ}\text{C}$; $\pm 0,8K$ for $-200...+850\text{ }^{\circ}\text{C}$ and 2- or 3-wire connection; $\pm 0,5K$ with 4-wire connection. Span start and end of span can be configured freely in steps of $0,1\text{ K}$ within the specified max. measuring ranges.

Lead resistance:

3- and 4-wire connection: $\leq 30\text{ Ohm}$ per lead

2-wire connection: 10 Ohm per lead
Sensor current: $0,5$ or $0,25\text{ mA}$, depending on sensor type.

Potentiometer

2-, 3- or 4-wire connection
Max. 4 kOhm

Smallest span: $\geq 6\text{ Ohm}$

Measurement error:

$\pm 150\text{ mOhm}$ up to 180 Ohm

$\pm 300\text{ mOhm}$ up to 390 Ohm

$\pm 2\text{ Ohm}$ up to 2000 Ohm

$\pm 4\text{ Ohm}$ up to 4000 Ohm

The measuring span can be configured freely in steps of $0,1\text{ Ohm}$.

Potentiometric transducer

3-wire connection

Max. 4 kOhm

Smallest span: $\geq 6\text{ Ohm}$

Measurement errors are the same as for potentiometers (above)

Direct voltage

Voltage signals with the following max. ranges can be measured:

Measurement range	Error
$-20...+70\text{ mV}$	$\pm 80\text{ }\mu\text{V}$
$-5...+105\text{ mV}$	$\pm 100\text{ }\mu\text{V}$
$-10...+210\text{ mV}$	$\pm 240\text{ }\mu\text{V}$
$-0,05...+1,2\text{ V}$	$\pm 1\text{ mV}$
$-0,5...+12\text{ V}$	$\pm 6\text{ mV}$
$-1,2...+12\text{ V}$	$\pm 2\text{ mV}$
$-12...+12\text{ V}$	$\pm 12\text{ mV}$

Smallest span: 5 mV

Span start and end of span can be configured freely within the specified measuring ranges. Up to 999 mV in steps of $0,01\text{ mV}$, and above 1 V in steps of 1 mV .

Input resistance:

$\geq 1\text{ MOhm}$ with inputs $\leq 210\text{ mV}$

$\geq 470\text{ kOhm}$ with inputs $> 210\text{ mV}$

Direct current

Current signals with the following max. ranges can be measured:

Smallest span: $0,5\text{ mA}$

Span start and end of span can be configured freely in steps of $0,01\text{ mA}$ within the specified max. measuring ranges.

Measurement range	Error
$-2...+22\text{ mA}$	$\pm 20\text{ }\mu\text{A}$
$-22...+22\text{ mA}$	$\pm 44\text{ }\mu\text{A}$

Voltage drop across input: $< 1,2\text{ V}$

Input circuit monitoring

Sensor	Break	Short circuit
Thermocouples	X	- (*)
Resistance thermometer	X	X
Potentiometer & pot. transducer	X	- (*)
Voltage $\leq 210\text{ mV}$	X	-
Voltage $> 210\text{ mV}$	-	-
Current	X	X

Sensor short circuit

X = is detected

- = is not detected

(*) is detected, if span start $> 100\text{ }^{\circ}\text{C}$ / $> 10\text{ Ohm}$

Digital inputs (option)

7 digital inputs to DIN VDE 0411, Part 500, max. 25 Hz , max. 32 V

Logic "0": $-3\text{ V}...+5\text{ V}$

Logic "1": $12\text{ V}...30\text{ V}$

Sampling rate: min. 1 s

Event counter

2 counters for max. 10.000 steps. Trigger signal, starting value, up/down counting, and text for event list are freely configurable, max. 25 Hz .

Sampling rate: min. 1 s

DISPLAY / OPERATION

STN colour display with a screen size of 145 mm ($5,7$ inches) and a resolution of 320×240 pixels. The display uses a 16-value grey scale and 27 colours.

Operation and configuration from the front by means of 8 keys, 5 of which are softkeys.

Configuration is also possible by means of an optional PC tool. Furthermore, the configuration can be read from the storage medium.

ALARM MONITORING

Min and max limits for each analog input, with freely adjustable hysteresis.

OUTPUTS

1 relay with changeover contacts: 230 V , 3 A

Transistor output (optional)
1 open-collector output: max. 25 V , max. 100 mA

Additional relays (optional)
 4 signalling relays with NC/NO contacts, 230 VAC , 3 A ; combined switching of safe low voltages (SELV) and mains voltages is not allowed.

Voltage source (optional)

Output: 24 VDC , 50 mA

POWER SUPPLY

Supply voltage

$93...263\text{ VAC}$, $48...63\text{ Hz}$

$20...30\text{ VUC}$, $0/48...63\text{ Hz}$

Supply voltage effect:

$< 0,1\%$ of max. measurement span

Consumption: approx. 25 VA

ENVIRONMENTAL CONDITIONS

Ambient temperature: $0...45\text{ }^{\circ}\text{C}$

Ambient temperature effect: $0,03\%$ /K

Storage temperature: $-20...+60\text{ }^{\circ}\text{C}$

Relative humidity: $\leq 75\%$, no condensation

CONFORMITY TESTS

CE marking

The unit complies with the relevant European Standards.

Electrical safety

According to DIN EN 61 010, Part 1 (March 1994)

Over-voltage category II

Contamination degree 2

Electromagnetic compatibility

Complies with EN 61326 A1

NAMUR recommendation NE21

GENERAL

Housing

Panel-mounting to DIN 43 700, of galvanized steel

Front dimensions: $200 \times 144\text{ mm}$ (W x H)

Depth behind panel: 225 mm

Panel cut-out: $138 \times 138\text{ mm}$ (see dimension drawing)

Panel thickness: $2...40\text{ mm}$

Fixing clamps to DIN 43 834

Protection class

To EN 60 529, Category 2

Front panel: IP 54

Rear: IP 20

Optional stainless steel front: IP 65

Data buffering

The RAM contents and the internal clock are buffered for at least 3 years by means of a Lithium battery (fitted by the supplier); if the optional buffer capacitor is used, the data are retained for 2 days (operating temperature 15...25 °C).

Configuration data are stored in a non-volatile EEPROM, and measurement data are saved on an external storage medium.

Mounting position

Vertical ±30, to DIN 16 257

Electrical connections

Plug-in screw terminals for leads with max. 2,5 mm² Interface: via 9-pin

Sub-D connector

Ethernet via RJ 45 socket

Weight:

3,5 kg

Accessories

3 operating instructions (E/D/F)

No.: 9499 040 76011 E

9499 040 76018 D

9499 040 76032 F

3 operating notes (E/D/F)

No.: 9499 040 76211 E

9499 040 76211 E

9499 040 76211 E

- 2 fixing clamps
- 1 set of screw terminals without Sub-D connector
- 1 CD (contents include device documentation and interface descriptions as PDF files (D/E/F))

1 cable tie

Description	Connector pin	Symbol
Supply voltage		
Supply voltage acc. to type label	N (L-) L1 (L+) PE	
Analog inputs		
Thermocouples	1 to 12	
Resistance thermometer Two-wire connection	1 to 12	
Resistance thermometer Three-wire connection	1 to 12	
Resistance thermometer Four-wire connection	1 to 12	
Potentiometric transducer	1 to 12	
Potentiometer in two-wire connection	1 to 12	
Potentiometer in three-wire connection	1 to 12	
Potentiometer in four-wire connection	1 to 12	
Voltage input 200 mV	1 to 12	
Voltage input >200 mV	1 to 12	
Current input	1 to 12	

Connecting diagram

Rear view with plug-in screw terminals

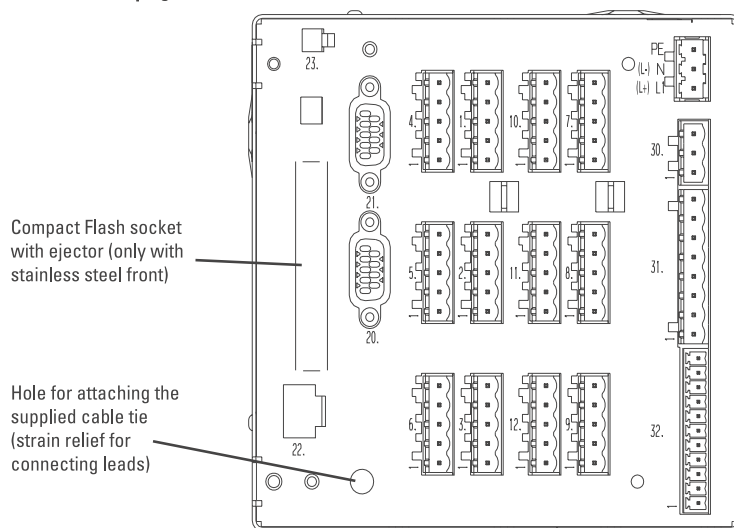

Description	Connector pins	Symbol
-------------	----------------	--------

Digital interfaces

RS 232 C 9-pin Sub-D socket	20	2 RxD receive data 3 TxD transmit data 5 GND ground
RS 422 9-pin Sub-D socket (optional)	20	3 TxD+ transmit data + 4 RxD+ receive data + 5 GND ground 8 TxD- transmit data - 9 RxD- receive data -
RS 425 9-pin Sub-D socket (optional)	20	3 TxD+/RxD+ transmit/receive data + 5 GND ground 8 TxD-/RxD- transmit/receive data -
Profibus DP 9-pin Sub-D socket (optional)	21	3 TxD/RxD-P transmit/receive data + 'line B' 5 DGND data ground 6 VP pos. supply voltage 8 TxD/RxD-N transmit/receive data - 'line A'
Ethernet RJ45 socket (optional)	22	1 TX+ transmit data + 2 TX- transmit data - 3 RX+ receive data + 6 RX- receive data -
Configuration interface	23	The data monitor also has a (parallel) setup interface port in the front panel. Only one interface may be used at a time.

Relay outputs

Relay K1 (changeover contact)	30	
Relays K2 to K5 (NO / NC contacts)	31	

Digital inputs/outputs

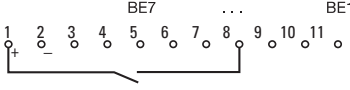
Open collector output (optional)	32 3 ground 4 collector	
Digital inputs (optional) voltage-controlled Low = -3...+5 VDC High = 12...30 VDC Supply 24 VDC, 50 mA	32 1 +24 V supply unstabilized 2 GND 5 digital input 7 ... 11 digital input 1	 Example: BE4, controlled by internal supply

Overall dimensions (also version with stainless steel front)

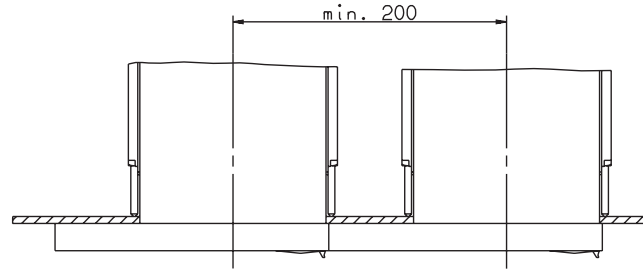
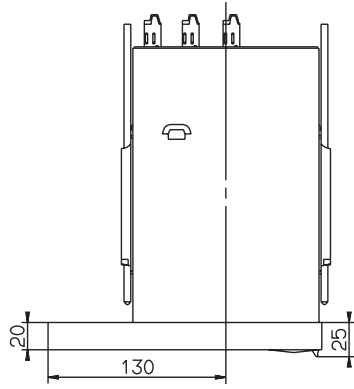
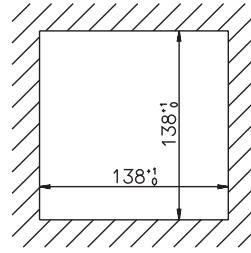
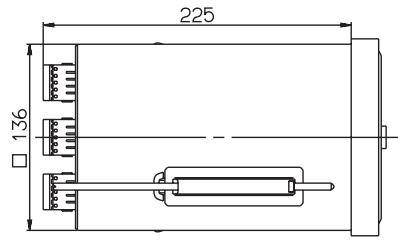
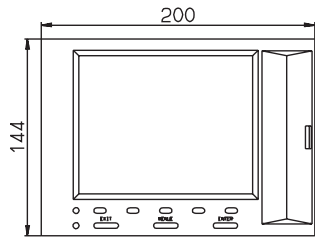

Universal transport housing and stainless steel front

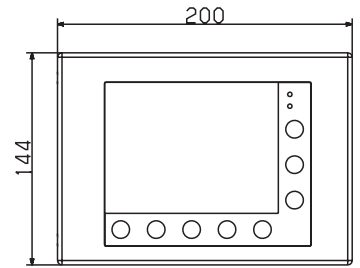
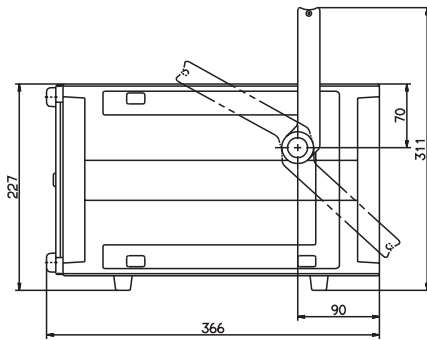
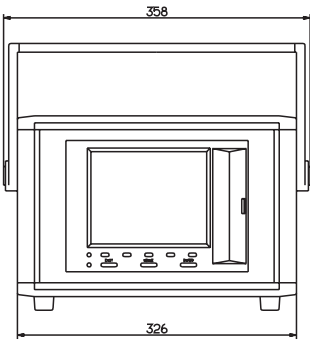

Versions

Order no.

Panel-mounted housing

Inputs

- 6 analog inputs
- 12 analog inputs without analog inputs (for Profibus DP)
- 6 analog inputs with stainless steel front IP 65 and foil keypad
- 12 analog inputs with stainless steel front IP 65 and foil keypad without analog inputs (for Profibus DP), stainless steel front IP 65 and foil keypad

External storage

- without external storage
- 64 Mbyte CompactFlash memory card
- 128 Mbyte CompactFlash memory card

Interface

- RS 232 (standard) + Ethernet
- RS 422/485 + Ethernet
- RS 232 and Profibus DP + Ethernet
- RS 422/485 and Profibus DP + Ethernet

Options

- 110...240 VAC
- 20...30 VUC
- 110...240 VAC + digital inputs/outputs (1)
- 20...30 VUC + digital inputs/outputs (1)
- 110...240 VAC + storage capacitor (2)
- 20...30V VUC + storage capacitor (2)
- 110...240 VAC + digital inputs/outputs (1) + storage capacitor (2)
- 20...30 VUC + digital inputs/outputs (1) + storage capacitor (2)

Internal storage

- 64 Mbyte backup memory
- 128 Mbyte backup memory

- (1) 7 digital inputs, 1 open collector output, 4 relay outputs, voltage output 24 VDC, 50 mA
- (2) Storage capacitor instead of the standard Lithium battery for memory buffering

Special versions

Universal transport housing

Software packages

- PCA 3000 evaluation software
- PCA communication server
- Engineering Tool KS 3012 (setup program)

Basic unit	Inputs	external storage	Interface	Options	internal storage
9407-303	x	x	x	x	x
	0				
	1				
	2				
	3				
	4				
	5				
		0			
		2			
		3			
			4		
			5		
			6		
			7		
				0	
				1	
				2	
				3	
				4	
				5	
				6	
				7	
					2
					3

9407-301 - 9 0 0 3 1

9407-303 9 0 2 0 1
 9407-303 9 0 2 1 1
 9407-303 9 0 2 2 1

