

ESB101

Made in Germany

Inrush Current Limiter, Inrush Current Protection

For capacitive loads, 115Vac/230Vac 16A, 16 ⅓ Hz – 440Hz, - 40°C...+70°C

Short Specification:

- Peak- / R.M.S. current limiter
- 90-130Vac / 184-265Vac, 16A continuous
- DIN TS35mm DIN-Rail
- Wall mount (universal housing)
- Springtype terminals 0,5-6mm² / 21-10AWG
- Integrated bypass relay
- Capacitive load 1.500uF bis 10.000uF
- Intergrated temperature protection
- IP20 UL94V-0 housing DIN43880 for DIN/VDE0603 cutout box

The ESB is a budget-priced inrush peak current limiter for high loads in LED-applications, complex automation systems and in the machine building. The ESB101 offers high recommended and interference free operation capacitive load. It is simple to integrate into existing equipment. The ESB101 is self- powering and does not require an external power supply.

16 ⅓ Hz – 440Hz

No simple NTC-solution! It allows to reduce cabling sections and to install fast circuit breakers. 100% protection from tripping pre-installed circuit breakers or burning multiplexer relay



Technical Table

Model	ESB101.05UPS	ESB101.16	ESB101.23	ESB101.23S	ESB101.33	ESB101.LED.230VAC	ESB101.LED.115VAC	ESB101.23S.115VAC
Peak Current Limiting $\pm 6\%$	5A	16A	23A	23A	33A	48A	43A	23A
R.M.S Current Limiting $\pm 6\%$	3,5A	11,3A	16,3A	16,3A	23,3A	33,9A	30,4A	16,3A
Allowed Capacitive Load (max.)	1.000uF	1.500uF	2.000uF	2.000uF	4.000uF	6.000uF	10.000uF	4.000uF
Limiting Time (T_{on} Power On)	900(± 50)ms	300(± 50)ms	300(± 50)ms	500(± 50)ms	300(± 50)ms	300(± 50)ms	300(± 50)ms	500(± 60)ms
Release Time (T_{off} Low Voltage)	1400(± 50)ms	500(± 50)ms	500(± 50)ms	800(± 80)ms	500(± 50)ms	550(± 50)ms	550(± 50)ms	900(± 80)ms
Limiting Interval [$T_{interval}$ for AC _{cont.}]	≥ 900 ms	≥ 900 ms	≥ 900 ms	≥ 1400 ms	≥ 900 ms	≥ 900 ms	≥ 900 ms	≥ 1400 ms
Smallest advisable Circuit Breaker at 30°C	A2A	A6A B4A Z6A	A10A B6A Z10A	A10A B6A Z10A	A13A B8A Z13A	B13A	A16A B13A Z16A	A10A B6A Z10A
AC Input Range	184-265Vac					90-130Vac		
AC Continuous Range	230Vac					115Vac		
Line Frequency	16 2/3 Hz – 440Hz					16 2/3 Hz – 440Hz		
Switch-On Voltage	144Vac					79Vac		
AC Lower Margin	52Vac (AC dump / drop)					28Vac (AC dump / drop)		
AC Continuous Current	16A continuous							
AC Peak Current	165A for 20ms / 800A for 200us capacity of the internal relay contacts while switching							
Power Supply	item is self-powering							
Current Consumption	19mA constant at continuous operation							
Limiting Cycles	3 cycles/minute							
Internal Protection	Thermal fuse protects overload & fire							
Cooling	Natural convection							
Operation Temp.	Ambient temperature -40°C...+70°C continuous / +75°C short time							
Storage Temp.	-40°C...+85°C for 2 years							
EMI	EN55022 class B							
EMS	EN61000-6-2,3							
Safety Norms	EN60950-1							
Safety Class II	VDE0805, VDE0100/ÖVE8001							
ROHS conformity	ROHS Directive 2011/65/EU							
REACH conformity	REACH Directive 1907/2006							
MTBF Calculation	300.000h (IEC/EN61709, Siemens SN29500)							
MTTF Calculation	384.000h (+30°C) (IEC/EN61709, Siemens SN29500)							
Humidity	95% (+25°C) not condensing							
Pollution Degree	2 (IEC/EN50178)							
Environmental	thermal environment 3K3, mechanics 3M4 (IEC/EN60721)							
Altitude max.	4000m (13123 ft.) above sea level							
Dimensions (WxHxD)	(2TE)36,5x110x62mm							
Housing Parameters	UL94V-0 ABS IP20 DIN/EN43880 universal housing for DIN/VDE0603 cutout box and for wall mount							
DIN-Rail	DIN-Rail TS35mm DIN/EN60715 (TS35/7,5 und TS35/15)							
Weight	121g / 0,27 lb							
Connections	Spring-type terminal with cable protection 0,5...6mm ² 21...10AWG according with IEC/EN60664-1, IEC/EN61984							

General Description

The CAMTEC ESB101-series are the 2nd generation and cost effective inrush current limiters. The limiters are made for 115/230Vac 16A networks. The line frequency range is 16½Hz – 440Hz. The ESB101-Limiter shall be located between the line-switcher/contactor and the load (p.2/Fig.1). The ESB-models are designed for capacitive loads. In the moment of switching-on the system the inrush current of the installed load will be limited for the defined time T_{on} (p.4/Fig.5). Independent from the previous inrush level; the current limiting is always strict. After T_{on} elapses the current limiting circuit of the ESB101 will be bypassed. Then the load is directly connected to the AC. The electrical network can be stressed with current loads as normal (e.g. motors, pumps). If an AC dump overshoots the defined time T_{off} , it will be detected by the ESB101 (p.4/Fig.6). As soon as the AC recovers the inrush will be limited, again (p.2/Fig.3 & 4). The ESB101-models provide an internal temperature control. In case of a failure the device shuts down to safely prevent from overheating or burning.

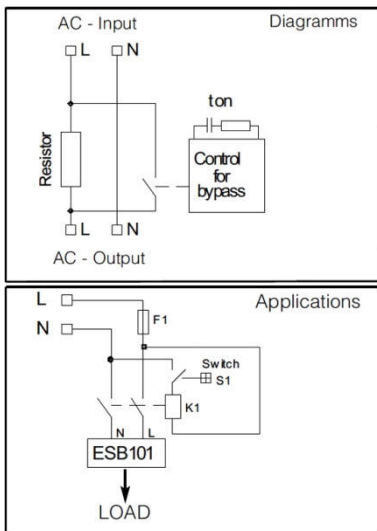

(Fig.1)

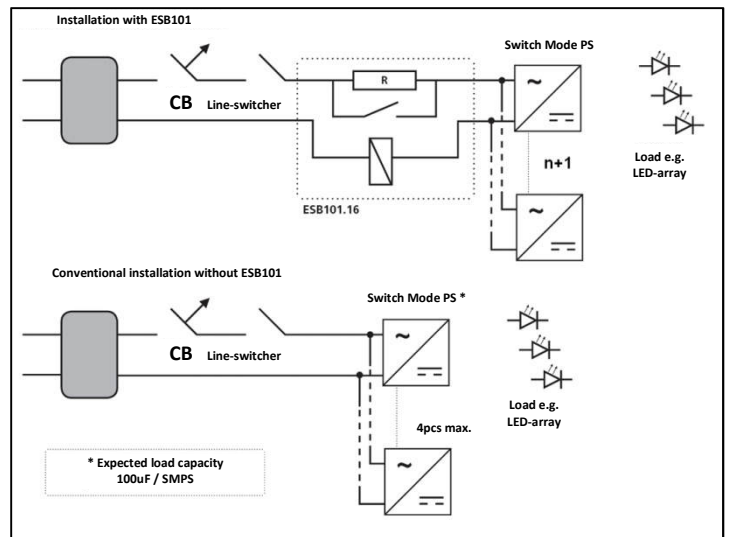

(Fig.2)

Field Applications

The ESB101 limiter allows connecting much more loads (e.g. LED-power supply / LED-driver) to a pre-installed circuit breaker CB (Fig.2). The ESB definitely avoids that the CB can be tripped. This occurs independent to the objective initial current. The result is that the number of A.C. branch lines and the pre-installed CB can be reduced dramatically. Installation cost exhibit a sustained decline.

Alternatively the cross section of the branch lines can be reduced when using smaller and faster responding circuit breakers. The cost saving from copper is essential. Sensitive AC networks can be fused safer (e.g. Traffic Control Systems, Street-Lighting, Parking Lots and Tunnels)

When the ESB101 is installed correctly, the neutral wire (N) is looped through (Fig.1). The inrush protection circuit always acts to the line conductor. The load is connected with the AC in such a way that a circuit breaker or an earth-leakage-trip works within the limits of the legal rules. This fact is also applied while the limiting circuit acts.

Special Models ESB101.LED with 115Vac & 230Vac

Compared to all other ESB101-models the LED-types are the universal inrush current limiters. The concept design is made to construct optimized A.C. networks in the building automation and in the lighting sector. Tripping the installed circuit breaker will be effectively prevented. The inrush limiting time is adjusted to the values of a typical LED power supply or LED-drivers. The connectable load capacity is such as high, that even in the extremes cases it is rather impossible to exceed it in a 16A network. Installed contractors will be discharged and their lifetimes will considerable increase. As well, the ESB101 LED-models are made to support the conventional lighting technology. The operation of an ESB101 with an electronic ballast leads to the same repeatable results. To protect the installed relay in a controlled DALI-/DMX-Multiplexer we advise to use the ESB101.23 for a 16A relay or the ESB101.16 for a smaller relay.

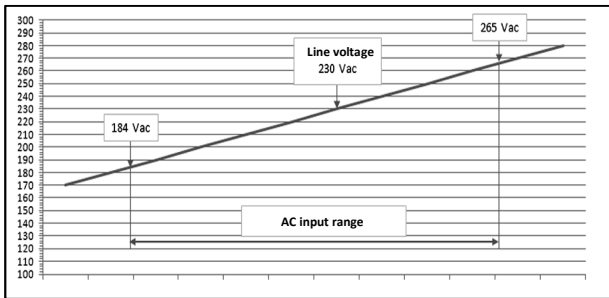

(Fig.3 operating range 230Vac)

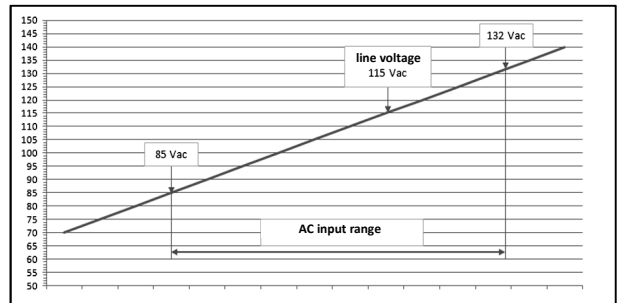

(Fig.4 operating range 115Vac)

Design-In of the ESB101 into A/C networks

The ESB101 models are the precise inrush current limiter with an overall tolerance of $\pm 6\%$ of the face value. For the dimension of an upstream connected circuit breaker the R.M.S is the key value of the inrush current, not the peak current. The thermal trigger point will not be met, even while using an extreme fast CB. All-dominant is the magnetic trigger current. By using the empirical formula $I_{(peak)} \times 0,707_{(factor)} = I_{(r.m.s.)}$ the tripping current can be defined fairly exact. Bear in mind that all the higher the inrush current is, all the faster the input capacitor of a number of connected switch mode power supplies will be loaded. Deduced by this fact we can say that within a 230V 16A A.C. network not the ESB101.16 limiter is the right selection for a CB B16A, but the ESB101.LED.230Vac. The technical table on page 2 shows the R.M.S value of all the ESB101 types and models.

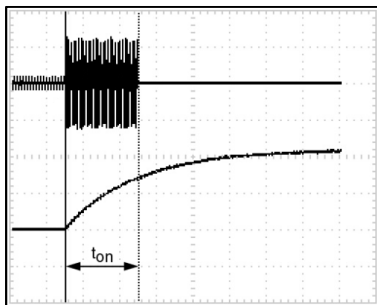

(Fig.5 limiting time T_{on})

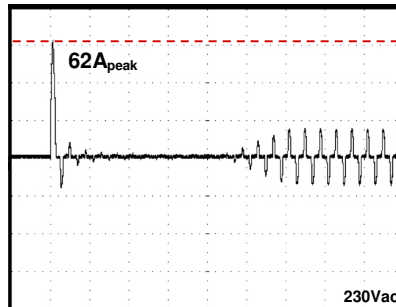

(Fig.7 inrush without ESB101)

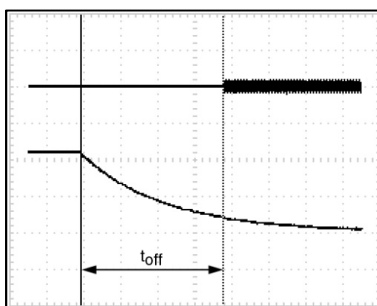

(Fig.6 AC dump detection T_{off})

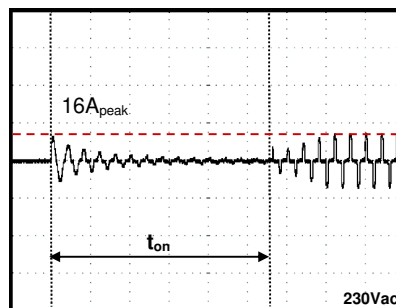

(Fig.8 inrush with ESB101)

Fig.7 and Fig.8

Fig.7 and Fig.8 show the typical start behaviour of a NTC protected switch mode power supply. The used test item is a CAMTEC HSE10001.24T with an output of 24V/42A (1008W) on DIN-Rail.

The peak current recordings show the precise limiting of the inrush from formerly $62A_{peak}$ to $16A_{peak}$. The corresponding R.M.S level, that is responsible for the magnetic tripping of the CB, is mark down by factor 0,707. After the time T_{on} elapsed it is identified that the power supply starts neatly into the continuous operation mode. Now the current is absorbed pulse-shaped from the AC. In detail the full load R.M.S. current consumption level of the HSE10001 hits 9A @ 230Vac.

Mechanics

IP20 housing (ABS UL94V-0) DIN 43880 with IEC standardized ventilation slots. Save fix on DIN-Rail TS35mm DIN/EN60715. It is designed for building cabinets DIN/VDE0603. Easy to wall mount by multifunctional housing; remove the DIN-Rail latch and access the two mounting holes to screw the ESB101 to any old surface.

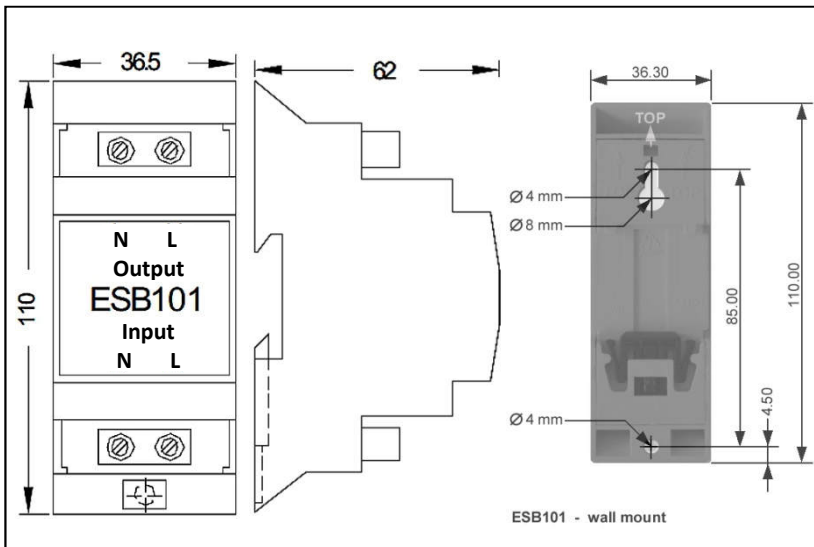

(Fig.9 mechanical drawing)

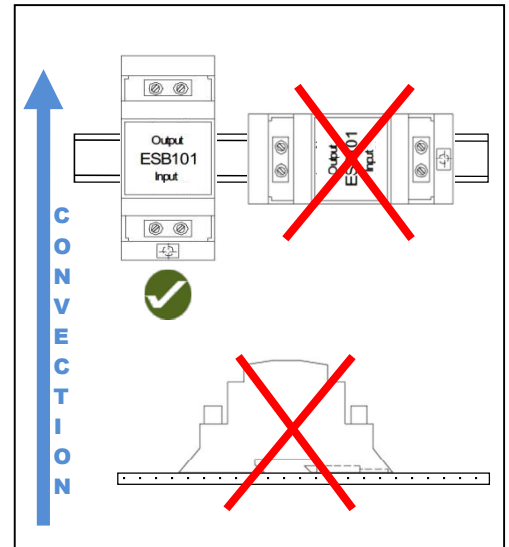

(Fig.10 mounting restriction)