

Laser Distance Measuring Device

LMC-J-0060

- Non contact distance measurement up to 100 Hz
- Broad measurement range up to 500m with mm accuracy
- Visibility measuring beam
- Industrial standard interfaces
- Option: Measuring on hot surfaces up to 1600°C (Steel 1450°C)



The laser distance meter LMC-J-0060 is robustly engineered especially for industrial applications. It works on reflector at distances up to 500 m. Up to 100 m (depending on target reflectivity) no special reflector is needed. Measuring values are provided continuously via the integrated interface RS232 / RS422 / 485 and analogue output 4... 20 mA.

As option ProfiBus, Ethernet TCP/IP WLAN and SSI interface are available.

Within the range of 500 m LMC-J-0060 provided an absolute measurement accuracy of ± 1 mm and a measurement frequency of up to 100 Hz.

The sensor alignment can be easily achieved with the help of the visible red laser beam.

The parameter settings for instance measuring frequency, average factor, serial port, measuring window, baud rate, auto start function etc. is to realized via the integrated serial data interface.

Due all of these functions this sensor is the best solution for nearly all industrial applications e.g. positioning, dimension measurement etc.

Features:

- Laser class 2
- Non-reflector measurement
- Millimeter accuracy measurement on any surfaces
- Serial Interface RS 232 ,RS 422 and 485
- Analogue output 4....20 mA
- Option: Profibus, SSI, Ethernet TCP/IP, W-LAN
- Easy installation and commissioning
- Meets IP 66 protection class for industrial use
- Modular housing system with different options
- Option: Measuring on hot surfaces up to 1600°C (Steel 1450°C)

Technical Data

Power supply	10 - 30 VDC
Power consumption	< 5W (with heating 15 W by 24 V)
Serial Interface	RS232 / RS422 / RS485
Analogue Interface	4 ... 20mA
Alarm output	3 high side switch, up to 0.2 A
Trigger	1 trigger in/output, 3V DC... 30V DC
Optional	ProfiBus, SSI, Ethernet TCP/IP, WLAN
Laser class	Class 2 (EN 60825-1:2007)
Wave length	$\lambda = 635$ nm
Divergence	< 0.35 mrad
Peak Power cw	max. 0.9 mW
Range*	0,1 ...500 m (reflector) 0,1... 100m (on natural surfaces)
Measuring time	10 ... 1000 ms
Accuracy (1σ)**	± 1 mm (± 3)
Resolution	0.1 mm
Connection	by industry jack
Material of housing	Aluminium
Protection class	IP 66
EMC	EN 61326-1
Temperature range	-10°C ... +50°C
With optional heating	-40°C ... +50°C
Dimension (LxBxH)	(235 x 90 x 110) mm
Weight	3,2 kg

*Depending on the surface, target reflectivity, stray light and environment condition
 **Depending of setting parameters, surface temperature and distance range



For surface temperature up to 1100°C:

Type	Interfaces
LMC-J-0060-1-1	RS232/RS422/RS485, 4 - 20 mA, 3 switching outputs
LMC-J-0060-1-2	SSI+RS232/RS422/RS485, 4 - 20 mA, 3 switching outputs
LMC-J-0060-1-3	Profibus + RS232/RS422/RS485, 4 - 20 mA, 3 switching outputs
LMC-J-0060-1-7	SSI+Profibus+RS232/RS422/RS485, 4 - 20 mA, 3 switching outputs
LMC-J-0060-1-4	Ethernet TCP/IP 3 switching outputs

For surface temperature up to 1600°C:

LMC-J-0060-2-1	RS232/RS422/RS485, 4 - 20 mA, 3 switching outputs
LMC-J-0060-2-2	SSI+RS232/RS422/RS485, 4 - 20 mA, 3 switching outputs
LMC-J-0060-2-3	Profibus + RS232/RS422/RS485, 4 - 20 mA, 3 switching outputs
LMC-J-0060-2-7	SSI+Profibus+RS232/RS422/RS485, 4 - 20 mA, 3 switching outputs
LMC-J-0060-2-4	Ethernet TCP/IP, 3 switching outputs

Options:

- Exchange window
- Double long front tube for better dust and spray material protection
- Water, -air or Peltier cooling for temp. up to +100°C
- Protection class IP67+vibration protection
- Heat shield
- Air purge
- Heating for temperatures to -40°C
- Customized outputs/interfaces (e.g. Ethernet TCP/IP, WLAN etc.) and housings

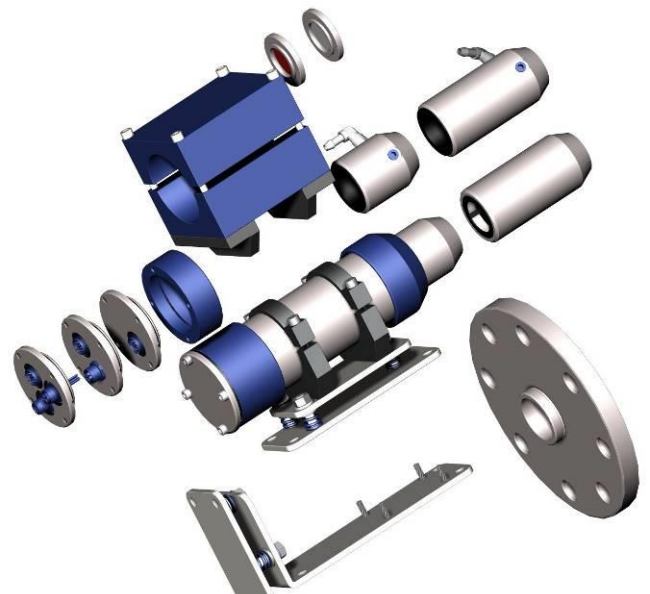

Dimensions:

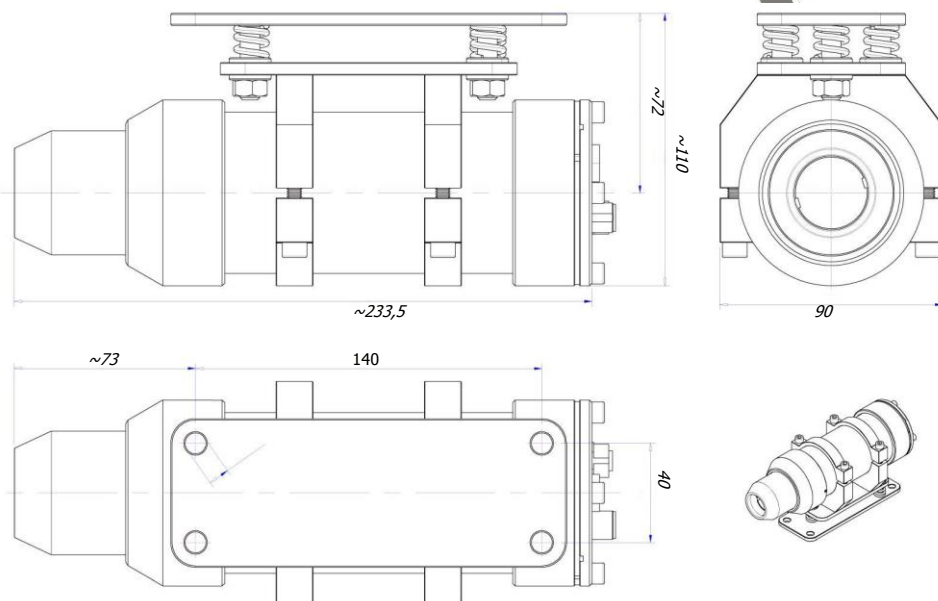

Kempf GmbH & Co KG
Otto-Hahn-Str. 5
69190 Walldorf

Tel: 06227/8220-0
Fax: 06227/8220-10
E-Mail: info@loke.de
Homepage: www.loke.de